

Programmable seven-channel RC encoder

NE5044

DESCRIPTION

The NE5044 is a programmable parallel input, serial output pulse width encoder. A multiplexed dual linear ramp technique is used to allow up to 7 inputs to be converted to a serial pulse width modulated signal with excellent linearity and minimal crosstalk. Fixed or variable frame rates can be used, externally controlled, for ease of demodulation. An on-board 5V regulator eliminates power supply sensitivities and provides up to 20mA current capability for driving external loads.

FEATURES

- 3 to 7 channels, externally selectable
- Constant-current dual linear ramp for linearity better than 0.3%
- Internal voltage regulator for low drift
- Wide supply range 4.5-12V
- Fixed or variable frame rate set by external RC
- External control for channel gain or range
- Versatile applications: exponential rates, mixing, dual rate, reversing, etc.
- Compatible with all transmission mediums

APPLICATIONS

- Radio-controlled aircraft, cars, boats, trains

PIN CONFIGURATION

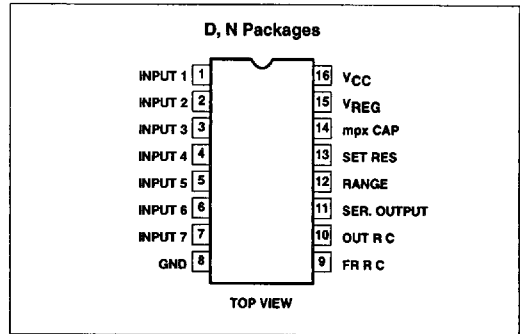

- Industrial controllers
- Remote-controlled entertainment systems
- Security systems
- Instrumentation recorders/controls
- Remote analog/digital data transmission
- Automotive sensor systems
- Robotics
- Telemetry

BLOCK DIAGRAM

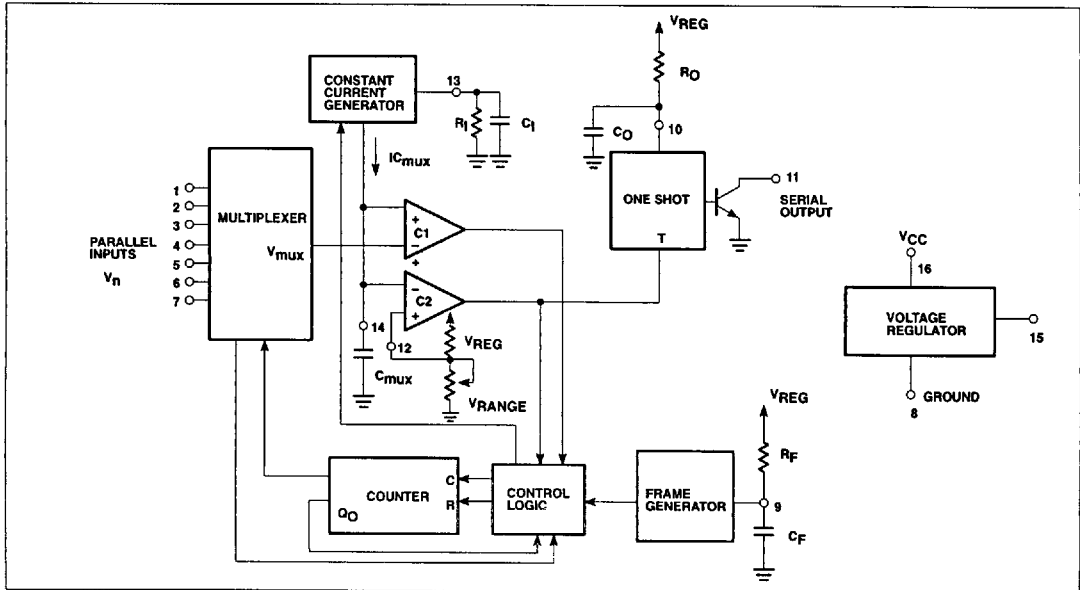

Programmable seven-channel RC encoder

NE5044

ORDERING INFORMATION

DESCRIPTION	TEMPERATURE RANGE	ORDER CODE	DWG #
16-Pin Plastic Small Outline (SO) Package	0 to +70°C	NE5044D	0005D
16-Pin Plastic Dual In-Line Package (DIP)	0 to +70°C	NE5044N	0406C

ABSOLUTE MAXIMUM RATINGS¹

SYMBOL	PARAMETER	RATING	UNIT
V _{CC}	Supply voltage	13	V
I _{OUT}	Regulator output current	-25	mA
	Serial output peak current	30	mA
	Constant-current generator	-1	mA
	Parallel inputs, range input	0-V _{REG}	V
	One-shot input, frame generator input	0-V _{REG}	V
T _A	Operating temperature range	0 to +70	°C
T _{STG}	Storage temperature range	-65 to +150	°C

NOTE:

1. T_A=25°C, unless otherwise stated.

DC ELECTRICAL CHARACTERISTICS

Test Conditions T_A = 25°C V_{CC}=10V using Test Circuit, unless otherwise stated.

SYMBOL	PARAMETER	TEST CONDITIONS	LIMITS			UNIT
			Min	Typ	Max	
Power supply requirements						
V _{CC}	Power supply voltage range		4.5		12	V
I _{CC}	Power supply current	Excluding control pots and serial output currents		11	15	mA
Voltage regulator						
V _{REG}	Output voltage		4.5	5.0	5.5	V
I _{OUT}	Output current	V _R ≥4.5V			-20	mA
	Line regulation	7≤V _{CC} ≤12		0.005	0.02	V/V
Multiplexer						
I _{IN}	Input current	V _I =2.5V		±30	±200	nA
V _{IN}	Input voltage range	V _I -V _{Range} ≥0.75V	1.5		5	V
	Crosstalk			±1	±5	µs

Programmable seven-channel RC encoder

NE5044

AC ELECTRICAL CHARACTERISTICS

Test conditions $T_A=25^\circ\text{C}$, $V_{CC}=10\text{V}$ using Test Circuit, unless otherwise stated.

SYMBOL	PARAMETER	TEST CONDITIONS	LIMITS			UNIT
			Min	Typ	Max	
Output pulse						
t_n	Position	$R_I \cdot C_{MUX}=1.25\text{ms}$ $V_n=0.5V_{REG}$; $V_{RANGE}=0.2V_{REG}$	1350	1500	1650	μs
	Position linearity error			5		μs
	Position tempco	$0^\circ\text{C} \leq T_A \leq 70^\circ\text{C}$		0.15		$\mu\text{s}/^\circ\text{C}$
	Position PSR	$6\text{V} \leq V_{CC} \leq 12\text{V}$		0.5	1	$\mu\text{s}/\text{V}$
t_O	Width	$R_O C_O=300\mu\text{s}$	240	285	330	μs
	Saturation voltage	$I_O=25\text{mA}$		0.6	1	V
I_{11}	Leakage current			0.05	50	μA
R_I	Range input voltage	$R_I=50\text{k}\Omega$ $R_I=25\text{k}\Omega$	0.75 1.00			V V
	Frame time (fixed)	$R_F C_F=30\text{ms}$	17	20	23	ms
	Inhibit threshold				0.4	V

TYPICAL PERFORMANCE CHARACTERISTICS

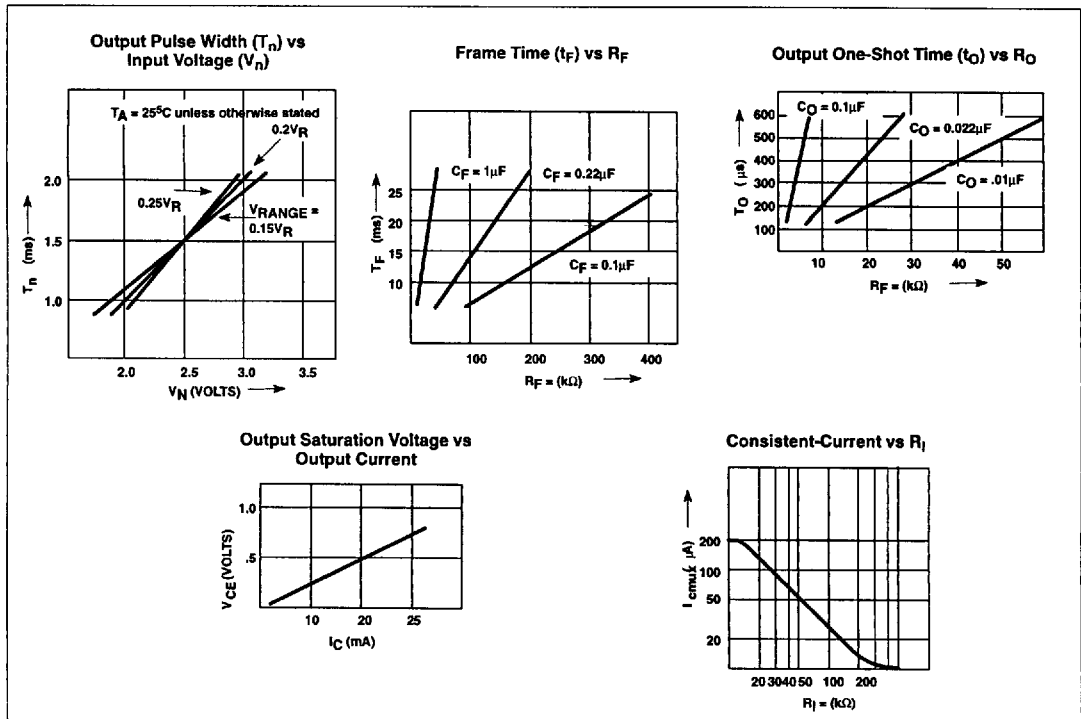

Programmable seven-channel RC encoder

NE5044

counter, and triggers the output one-shot. C_{MUX} again charges up but now C1 goes high when C_{MUX} reaches V_2 , the voltage on Pin 2. The resulting voltage waveform on C_{MUX} is a triangle wave whose positive peaks correspond to the voltages on Pins 1 through 7 for the first through seventh peaks and whose negative peaks are constant and equal to V_{RANGE} . This waveform is shown in the first portion of Figure 1.

Independent control of I_C and V_{RANGE} allows the encoder to be tailored to virtually any combination of input voltage changes and output pulse width changes. The functional relationships between these variables will be defined in the next section.

The frame generator controls the encoder frame time. It can operate as an astable or monostable multivibrator whose period is $0.66 \times R_F \times C_F$. The encoder will generate a synchronizing pulse at the end of each frame. When C_{MUX} reaches the seventh positive peak it reverses and discharges to V_{RANGE} . The counter is clocked to the state where Q_0 is high when $V_{CMUX} = V_{RANGE}$. C_{MUX} again charges up, but now the output of C1 is ignored, due to Q_0 being high, and charges up to V_{CLAMP} and remains there. The encoder will remain in this state until a pulse from the frame generator is received. If R_F and C_F are connected as shown in the Block Diagram, then the frame generator operates in the astable mode, producing a narrow pulse output. This pulse allows C_{MUX} to start discharging again. When C_{MUX} reaches V_{RANGE} , the counter is clocked to the state where Q_1 is high (channel 1) and the entire process starts over. The frame period in this mode is $0.66 \times R_F \times C_F$ and is referred to as the fixed-frame mode. The variable-frame mode will be discussed in the application section.

The output one-shot generates a positive pulse whose width is equal to $R_0 C_0$. The output is an open-collector, NPN transistor capable of sinking 25mA. This configuration allows the encoder to drive a wide variety of RF stages as well as providing current pulses in 2-wire communications applications.

ENCODER DESIGN EQUATIONS

The triangular waveform on C_{MUX} has a fixed slope (constant current) and variable positive peak voltages. The time between the negative peaks of C_{MUX} , which is equal to the output period for that channel, is given by:

$$t_n = \frac{2 (V_n - V_{RANGE}) C_{MUX}}{I_C}$$

I_C is given by:

$$I_C = \frac{V_R}{2R_1}$$

where V_R = Reference Voltage.

Additionally, V_n , the voltage on Pin n, which is the control voltage for Channel n, is typically the wiper voltage on a pot connected between V_R and ground. Thus $V_n = X_n V_R$.

V_{RANGE} is also derived from V_R so that $V_{RANGE} = Y V_R$. The resulting channel time period is:

$$t_n = \frac{2 (X_n - Y) V_R \cdot C_{MUX}}{(V_R / 2R_1)}$$

$$t_n = 4R_1 C_{MUX} (X_n - Y)$$

Thus, each channel pulse width, t_n , is independent of supply voltage and depends only on external passive components.

The conversion rate, CR, for each channel is the change in output period, Δt_n , divided by the change in input voltage for that channel, ΔV_n .

$$CR = \frac{\Delta t_n}{\Delta V_n} = \frac{\Delta t_n}{\Delta X_n} = 4 R_1 C_{MUX}$$

In most applications, the input variable X_n will have some neutral or center value about which it will vary, thus $X_n = X_0 + X_n$,

and

$$CR = \frac{\Delta t_n}{\Delta X_n} = 4R_1 C_{MUX}$$

Where X_0 is the neutral value for X and is assumed to be the same for all n. Now

$$t_n = 4R_1 C_{MUX} (X_0 + Y + X_n)$$

If we let $t_{NEUTRAL} = 4R_1 C_{MUX} (X_0 + Y)$ be the neutral value for t_n , then

$$t_n = t_{NEUTRAL} + 4R_1 C_{MUX} (X_n)$$

Consider the following example to see how these design equations are used.

Assume:

$$t_{NEUTRAL} = 1.5ms$$

$$X_0 = 0.5 \text{---Control pot in center at}$$

$$t_n = t_{NEUTRAL}$$

$\Delta X_n = \pm 0.1$ ---Control pot resistance varies $\pm 10\%$ (of total resistance) around neutral. This should include mechanical trim if used.

$$\Delta t_n = \pm 0.5ms$$

For this example, the conversion rate is

$$CR = \frac{\Delta t_n}{\Delta X_n} = \frac{0.5ms}{0.1} = 5ms$$

so

$$4R_1 C_{MUX} = 5ms.$$

If we let $C_{MUX} = 0.047\mu F$ then

$$R_1 = \frac{5ms}{4 \times 0.047\mu F} = 26.5k\Omega = 27k\Omega$$

and

$$t_{NEUTRAL} = 1.5ms = 4R_1 C_{MUX} (X_0 + Y)$$

$$Y = 0.5 - \frac{1.5ms}{5ms} = 0.2$$

The output pulse width is given by

$$t_0 = R_0 C_0$$

so if $t_0 = 330\mu s$ and $C_0 = 0.01\mu F$ then

Programmable seven-channel RC encoder

NE5044

$$R_O = \frac{330\mu s}{0.01\mu F} = 33k\Omega$$

The frame time constant, t_F is given by

$$t_F = 0.66 R_F C_F$$

If $t_F = 20ms$ and $C_F = 0.47\mu F$

$$R_F = \frac{20ms}{0.66 \times 0.47\mu F} = 62k$$

Figure 2 shows the external connections for this example.

It should be noted that the temperature stability of all the encoded times depend on the temperature coefficients of the respective external R_C time constants. No internal temperature compensation is used on the chip. The typical temperature sensitivity of t_n using wirewound resistors and polycarbonate capacitors is less than 100ppm/°C in the -20°C to +70°C temperature range. For the above example, this corresponds to a change in t_n of $\pm 7.5\mu s$ for a change in temperature of $\pm 50^\circ C$.

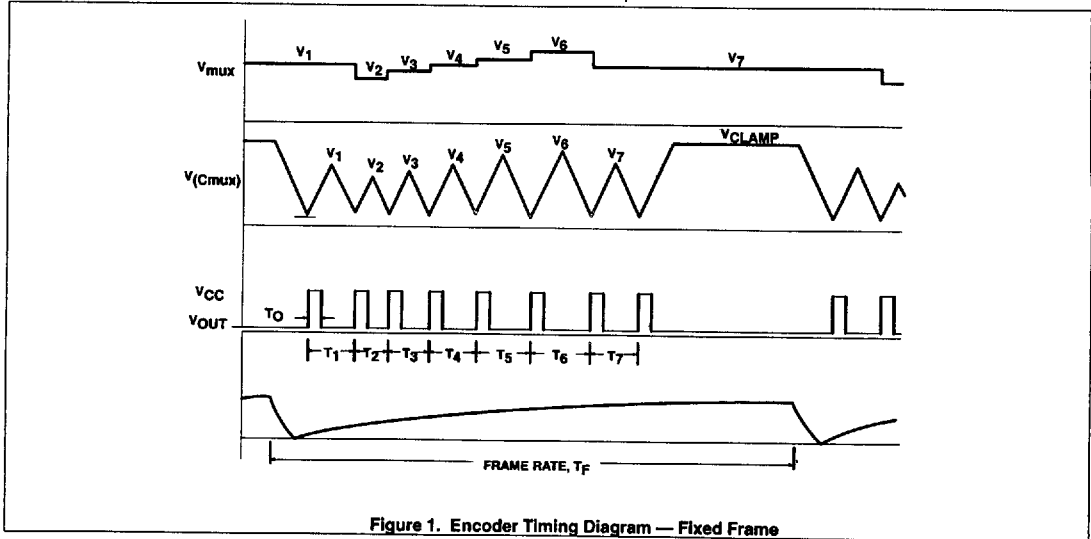

Figure 1. Encoder Timing Diagram — Fixed Frame

Programmable seven-channel RC encoder

NE5044

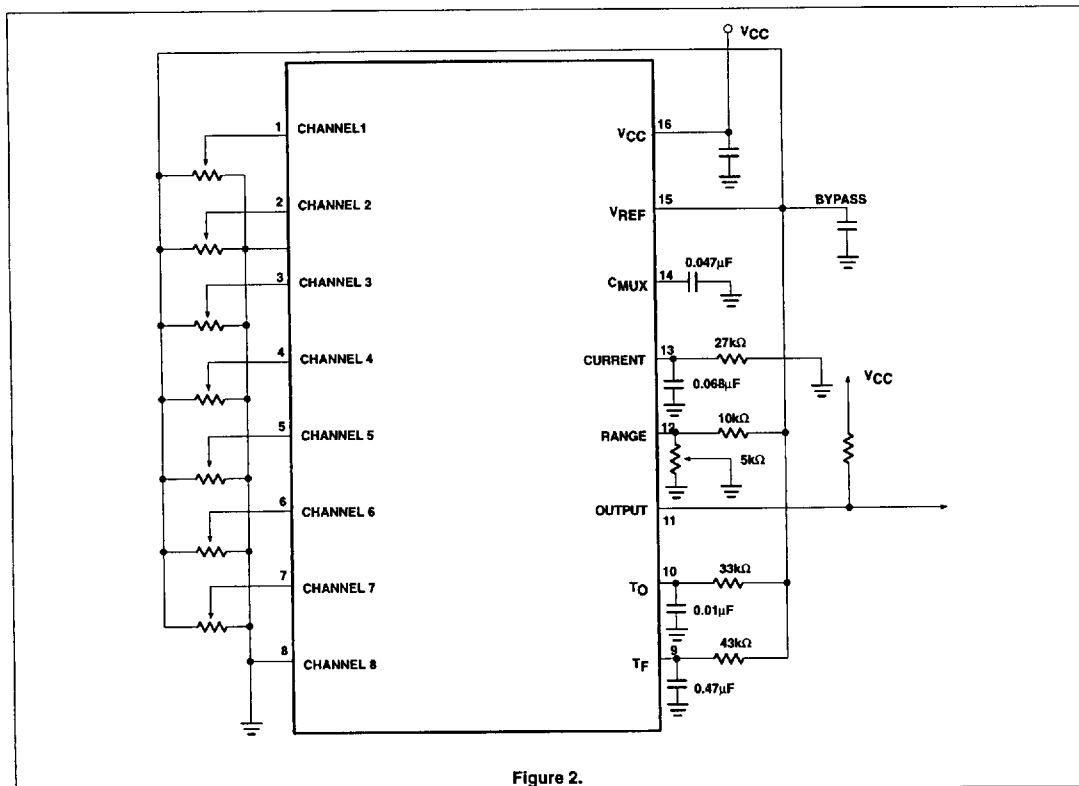

Figure 2.